

J. A. De VRIES.
Jewelers' Lathes.

No. 196,077.

Patented Oct. 16, 1877.

Fig. 1.

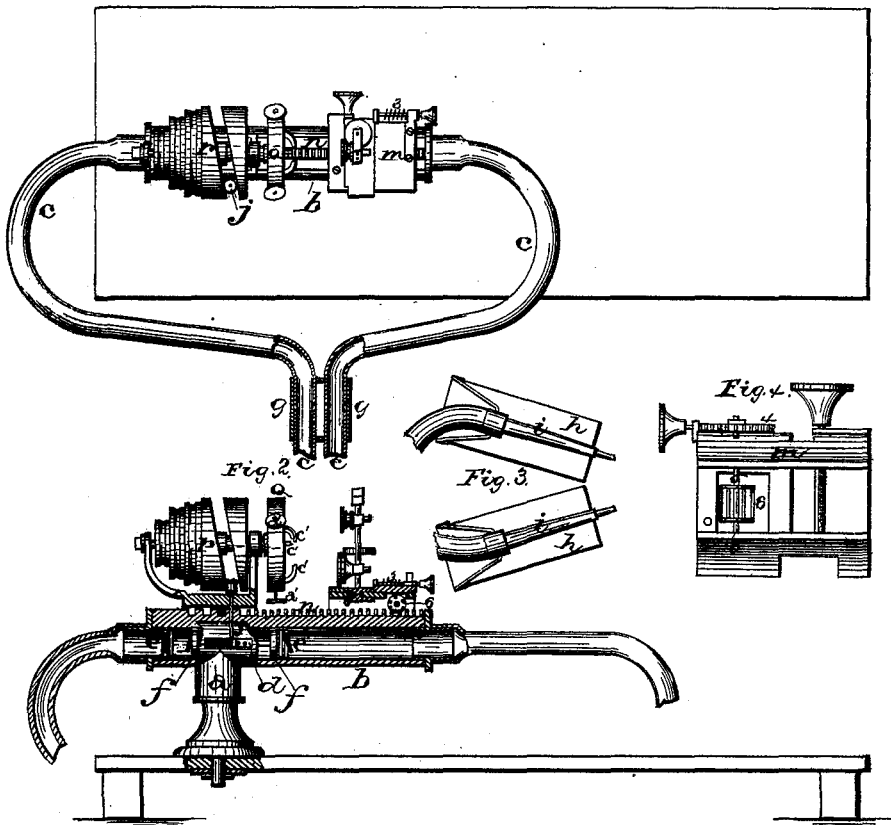

WITNESSES

J. W. Garner
Will. H. Kern

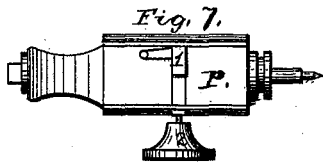

INVENTOR.

J. A. de Vries
per
F. W. Lehmann
Atty

UNITED STATES PATENT OFFICE.

JELLE ANDRIES DE VRIES, OF PELLA, IOWA, ASSIGNOR OF ONE-HALF HIS RIGHT TO A. KRUIDENIER, OF SAME PLACE.

IMPROVEMENT IN JEWELER'S LATHES.

Specification forming part of Letters Patent No. **196,077**, dated October 16, 1877; application filed August 15, 1877.

To all whom it may concern:

Be it known that I, JELLE ANDRIES DE VRIES, of Pella, in the county of Marion and State of Iowa, have invented certain new and useful Improvements in Lathes for Jewelers, and light work of various kinds; and I do hereby declare the following to be a full, clear, and exact description of the invention, such as will enable others skilled in the art to which it pertains to make and use it, reference being had to the accompanying drawings, which form part of this specification.

My invention relates to an improvement in lathes for jewelers and light work of various kinds; and it consists in the arrangement and combination of parts, that will be more fully described hereinafter.

The accompanying drawings represent my invention.

a represents the standard, upon the top of which is placed the tubular bed-piece *b*, which is open at both of its ends, and has attached to each one the rubber tube *c*. The standard *a* being pivoted, the bed-piece *b* can be turned horizontally around in all directions. Through the side of this bed-piece is cut a slot, and through this slot is inserted a small sliding block, *d*, which is fastened to the tubular piston *f*; that works back and forth inside of the bed *b*. This piston is provided at each end with outwardly-opening valves, and is used to force air through the rubber tubes *c*, for the purpose of doing soldering-work. In each end of the bed-piece are placed the valves *e*, which also open outwardly, and serve to prevent the air from returning into the bed-piece after it has been forced out by the piston. Passing over both of the rubber tubes *c*, at any suitable distance from their ends, is the air-chamber *g*, and inside of this air-chamber there are holes made through the hose, so that a portion of the air will escape from the tubes and enter this chamber. The pressure in this chamber will serve to equalize the force of the blast from both tubes, for in case one tube should be receiving more air from the piston than the other this surplus air will pass from the air-chamber and into the other tube, and thus both tubes would have about the same volume of air passing through them. In order that

the hands may be left free to operate the work as expeditiously and neatly as possible, each one of the nozzles *i* is provided with a rest or support, *h*, by means of which they can be adjusted to any position, and thus deliver their air upon the piece being soldered without requiring any further attention on the part of the operator. These rests consist of the base-plates and spring-arms, the said arms being made to snap into little recesses in the sides of the nozzles, and thus support them. Fastened to the slide-block *d* is an arm, *j*, which has a friction-roller upon its upper end, and this roller fits in the eccentric slot made in the side of the spindle *r*. The spindle having been set in motion, the eccentric slot causes the arm *j* to move the block back and forth in the slot, and thereby operate the piston, as already described. As the arm *j* is pivoted to the block, when it is not desired to operate the pump it is only necessary to throw the arm back out of gear with the spindle *r*.

By thus combining the air-forcing apparatus or bellows for soldering with a lathe a very large additional range of work is given to the lathe, and that without in any way interfering with the operation of any of the other parts. Upon the top of the bed-piece *b* is made a wide dovetailed-flange, over which flange the different attachments that are to be used upon the lathe catch. In the lower part of the spindle is made a dovetailed groove for catching over the top of this flange, and passing through this groove is the spring-catch *1*, which is operated by means of the clamping-screw *2*. This spring-catch is made to snap into the teeth of the rack *n*, which runs the full length of the bed-piece along its center. By slightly unscrewing the clamping-screw, and then pressing inward upon the head, the catch will be moved out of the tooth, and then the spindle can be moved back and forth along the bed at will. By moving the spindle forward upon the bed so that the catch snaps into the third tooth, the eccentric slot in the spindle is brought just opposite where the arm *j* will be in position to work the piston back and forth. The slide-rest *m* also catches over the top of the dovetailed flange upon the top of the bed-piece, and is worked back and forth by means

of the worm 3, which meshes with the wheel 4, upon the outer end of the shaft 5. Upon this shaft 5, inside of the rest, is placed the pinion 6, which meshes with the teeth of the rack *n*, and thus the rest can be readily adjusted back and forth. Projecting outward from the inner end of the spindle-shaft is a screw, upon which the chuck *Q* is screwed. This chuck consists of a hollow frame, which has its outer face slotted from near its outer circumference to down near its center, in two or more places. Moving in these slots upon the adjusting-screws are the jaws which hold the article being operated upon. The rear plate *r'* of this frame is made movable, so that the screws *a'* and jaws *c'* may be taken out, the jaws removed from the screws, and reset in the opposite direction.

It will be seen from the shape of the end of each one of these jaws that when the jaws are all turned toward the center they are adapted for holding small articles, but when the points are turned outward they will receive articles of quite large size.

By thus having reversible jaws all kinds of work can be done upon this lathe, instead of having to have a number of different-sized chucks.

Having thus described my invention, I claim—

1. The combination of a hollow bed-piece, *b*, piston *f*, moving back and forth therein, the arm *j*, and a slotted spindle, *r*, substantially as specified.

2. The combination of the bed-piece *b*, piston *f* and operating mechanism, and a tube, *c*, the said tubes being provided with an air-chamber, *g*, substantially as set forth.

3. The combination of the tubes *c* and an air-chamber, *g*, the chamber being passed over both tubes, and both tubes being perforated, so as to cause the air in the chamber to equalize the pressure of the air as it escapes from both of the nozzles, substantially as shown.

4. The combination of the rest *h*, provided with the movable spring-jaws which catch the nozzle *i* and support it in any desired position, substantially as described.

5. The spindle *k*, made adjustable back and forth upon the top of the bed-piece *b*, and provided with a clamping device consisting of the spring-catch 1 and screw 2, for holding it in position, substantially as described.

In testimony that I claim the foregoing I have hereunto set my hand this 1st day of August, 1877.

JELLE ANDRIES DE VRIES.

Witnesses:

A. KRUIDMIER,
HENRY NOLLEN.